



Torque Limiter 200 Series

For more than 80 years, Autogard® products have led the industry in overload protection with high-quality products, design innovation and production. Autogard products are manufactured to meet ISO 9001 using the latest machine tools and high-quality materials.

Acting like a mechanical “fuse” to protect the weakest member of the drive train, the most effective location for Autogard Torque Limiters is as close as possible to the component being protected. The 200 Series is a state-of-the-art mechanical device that will disengage at a preset torque value. The trip torque is set above the normal startup and operating torque, but below a torque setting that would normally damage the driving and/or driven equipment. In the event of a jam, the 200 Series eliminates the threat of damage by disconnecting the inertia in the drive train.

In the normal drive condition, torque is transmitted through the drive balls ‘A’ which are seated in detents in the drive plate ‘B’ and the slide plate ‘C’. These are all held together under pressure from spring ‘D’.

Disengagement on Overload

When the driven machine either jams or an overload occurs that is greater than the torque setting, the balls roll out of their seats and force apart the drive plate ‘B’ and the slide plate ‘C’. The balls are retained by the cage plate ‘E’ and roll freely on the flat surface of the drive plate ‘B’ and slide plate ‘C’.

Re-engagement

Re-engagement occurs in one of three ways depending upon which reset type is selected.

Type AC — Automatic Random Reset

The ball detents in the drive plate ‘B’ and the slide plate ‘C’, as well as the retaining holes in cage plate ‘E’ are equally spaced on the same pitch circle diameter so that the balls will roll into the next detents after tripping in either direction. Immediate shutdown is required to prevent wear of the detents.

Type ACT — Automatic Single Position Reset

The ball detents are positioned in a scattered pattern so that the balls must return to their original position before they can reset. Re-engagement will occur within two revolutions in either direction. Immediate shutdown is required to prevent wear of the detents.

Figure 1

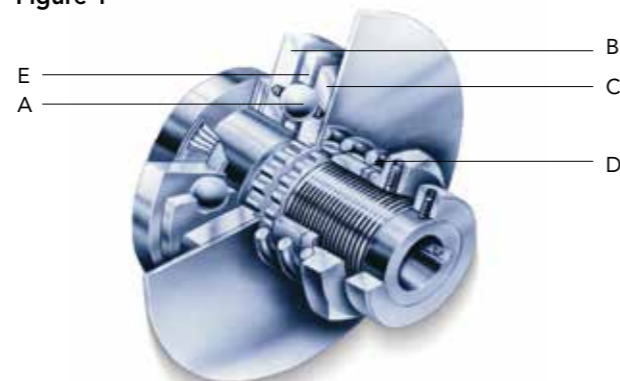

Letters above correspond to paragraphs on the left and below.

Type AF — Free Wheeling Disengagement

As with Type AC, the detents in drive plate ‘B’ and slide plate ‘C’ are equally spaced. The retaining holes in the engagement plate ‘E’ are elongated so that, as the balls roll from the detents, they can follow a cam profile onto a different running track away from the detents. Type AF can run at higher speeds as the balls will not ratchet in the detents. Resetting is achieved by manually locking the plates and reversing the drive.

Figure 2

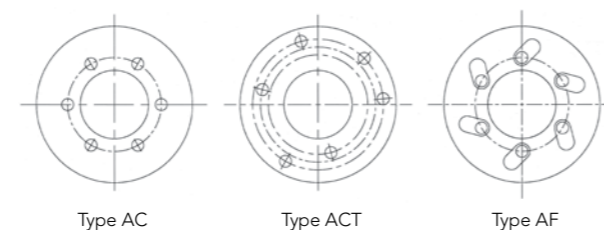

Features and Benefits:

- Proven design with thousands of units successfully in operation
- Accurate torque limitation prevents costly downtime
- Cost-effective design
- Standard designs can accommodate large torque ranges
- Instantaneous disengagement protects equipment from damaging inertias
- Bi-directional protection
- Easy to adjust to desired allowable torque
- Three reset types offered:
 - Type AC — Automatic Random Reset
 - Type ACT — Automatic Single Position Reset
 - Type AF — Freewheeling, Manual Reset for high speeds
- Wide range of mounting configurations ensures the right solution for any problem:
 - Timing, HTD and V-Belt drives
 - Chain and sprocket drives
 - Gear drives
 - Flexible or rigid couplings
 - Flywheel or large gear mounting

Selection:

Data required for torque limiter selection:

- Application details for service factors
- Kilowatt (kW) and rpm of the driver
- Shaft details of the driving and driven equipment

(1) Calculate the nominal torque.

$$\text{Torque (Nm)} = \text{Kw} \times 9550 / \text{rpm}$$

Consideration should then be given to start torque or other special circumstances depending on the position chosen in the drive system. Choose a set torque with a suitable margin over nominal. Select the torque limiter which has a higher torque rating.

(2) Check limiting conditions:

- Check hub bore capacity
- Check the torque limiter dimensions such as the overall length and outside diameter

(3) Select and specify the appropriate drive medium or coupling.

All 200 Series units may be supplied from the factory at a pre-set torque and with the required drive medium assembled to the unit.

Ordering the 200 Series Torque Limiter

When ordering, please provide the following designation:
Model and Size / Type / S1 bore / S2 bore
Standard bore tolerance = H8 + normal fit key

Example: 205-5 / AC / S1-60mm / S2-90mm

Refers to Model 205, Size 5, Automatic Random Reset
S1 Bore = 60mm S2 Bore = 90mm
Also specify setting torque is required.

The specifications contained within this brochure are correct at the time of going to print. Rexnord is continually reviewing and updating the specifications on its entire Autogard product offering and therefore reserve the right to change any detail.

Model 221

Figure 3

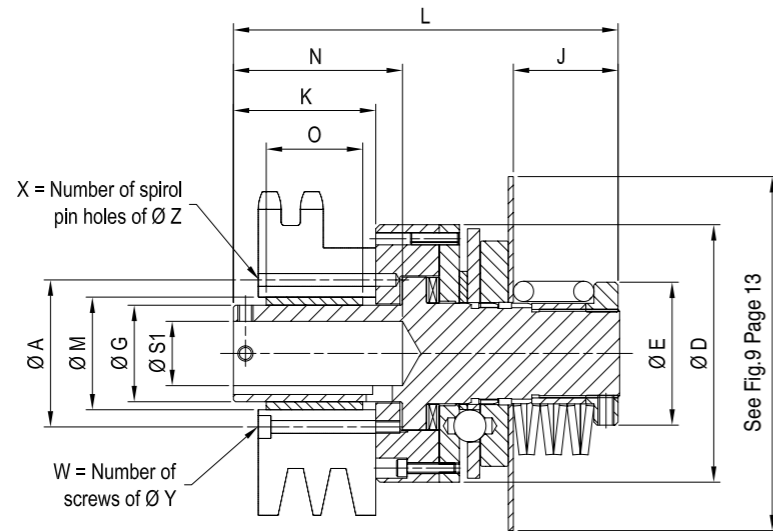

Table 1

Size	Torque ①		Speed ②			Weight ③	Mass Moment of Inertia MR ² ④
	Type AC or AF	Type ACT	Type AC	Type ACT	Type AF		
	Nm	Nm	rpm	rpm	rpm	Kg	Kgm ²
1	1-44	3-69	200	500	2,000	1.5	0.0005
2	6-226	9-384	200	500	2,000	4.5	0.0049
3	6-678	9-854	200	500	2,000	9.9	0.0150
4	90-1,130	113-1,774	200	500	2,000	21.6	0.0600
5	141-2,540	158-2,937	200	500	2,000	50.0	0.2100
5S ⑤	938-7,627	1,130-8,474	200	500	-	106.0	0.7300

- ① See page 14, Table 19 for spring selection and torque range with specific springs.
- ② Higher speeds may be allowed under certain conditions. Please consult Rexnord.
- ③ 5S is available in Type AC and ACT resets only.
- ④ Weights and moments of inertia apply to maximum S1 bores and exclude sprockets, etc.

Table 2

Model 221, for use with sprockets, pulleys or gears. Supplied complete with bearing and suitable mounting holes.

Size	Max. Bore S1 ①	D	E	Min. G ②	Max. G ②	J	K	L	Min. M ③	Max. M ③	N ④
	mm	mm	mm	mm	mm	mm	mm	mm	mm	mm	mm
1	12.7	60	33	22.225	22.253	42	50	140	25.400	25.430	51
2	25.4	102	57	38.100	38.136	42	56	153	44.450	44.475	67
3	38.1	127	80	50.800	50.838	76	78	216	57.175	57.201	89
4	50.8	159	108	71.476	71.501	96	117	287	77.788	77.818	127
5	76.2	216	153	101.727	101.752	121	148	368	114.300	114.336	165
5S	102	267	178	152.400	152.464	121	166	426	171.450	171.491	178

- ① Bores are furnished for clearance fit unless otherwise specified by customer. Please consult Rexnord.
- ② The drive medium may be mounted onto the adapter with screws and dowels and must be bored to dimension "M". The supplied bearing may then be press fitted into the drive medium. Finally, the bearing should then be bored to dimension "G" as shown.
- ③ Dimension N is depth of blind bore S1 as normally furnished, unless otherwise specified. For through-shaft applications or for weight reduction, through-bore can be furnished for an extra charge. The bore beyond depth N will be to a dimension larger than the finish bore of length N.

Table 3

Size	Smallest Sprocket (No. of Teeth)					Smallest Sheave Diameter ①
	3/8" pitch	1/2" pitch	5/8" pitch	3/4" pitch	1" pitch	
1	19	15	12	-	-	44
2	26	21	17	15	12	67
3	31	24	20	17	13	80
4	-	31	25	21	17	109
5	-	41	33	28	22	149
5S	-	60	48	41	31	230

① The diameter quoted is to the bottom of a V-sheave groove or to the inside diameter of the flange of a timing belt pulley. For sprockets, the above information applies only to a single strand chain. For multiple strand chain.

Table 4

Size	Standard Mounting Hole Patterns (Min. Diameters) ②					
	Dowels (X) ①		Screws (W) ①		A (PCD) mm	O mm
	No. of dowels	Dowel dia.	No. of Screws	Screw Size		
1	3	4	3	M4	36	38
2	3	5	3	M5	58	38
3	3	6	3	M6	70	63
4	6	8	3	M8	95	75
5	6	10	3	M10	135	100
6	3	12	3	M12	205	135

- ① Bolt holes to be equally spaced on bolt circle diameter specified. Care must be taken not to drill into other mounting holes in adapter.
- ② Standard mounting holes furnished for a standard price adder. Special mounting holes quoted upon request. Please consult Rexnord.



Model 202

Figure 4

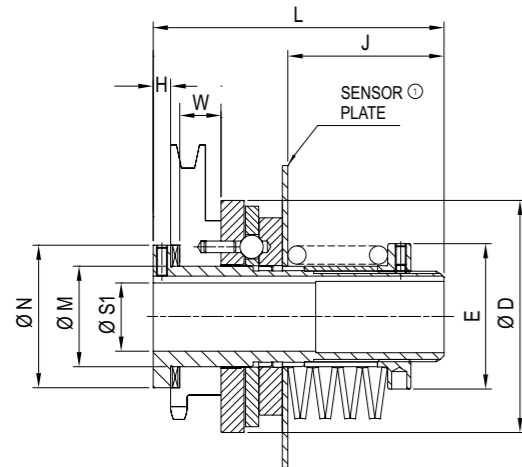

① See page 13, Table 18 for dimensions and movement on disengagement.

Table 5

Size	Torque ①		Speed ②			Weight ③ Kg	Mass Moment of Inertia MR ² ④ Kgm ²
	Type AC or AF Nm	Type ACT Nm	Type AC rpm	Type ACT rpm	Type AF rpm		
1	1-44	3-69	200	500	2000	1.0	0.0003
2	6-226	9-384	200	500	2000	2.9	0.0030
3	6-678	9-854	200	500	2000	6.4	0.0090
4	90-1,130	113-1,774	200	500	2000	15.4	0.0460
5	141-2,540	158-2,937	200	500	2000	33.4	0.1400
5S⑤	938-7,627	1,130-8,474	200	500	-	67.0	0.4700

- ① See page 14, Table 19 for spring selection and torque range with specific springs.
- ② Higher speeds may be allowed under certain conditions. Please consult Rexnord.
- ③ Weights and moments of inertias apply to maximum S1 bores and exclude sprockets, etc.
- ④ 5S is available in Type AC and ACT resets only.

Table 6

Model 202 supplied with a sprocket, pulley or gear as an integral part of the unit to give the shortest overall length.

Size	Max. Bore S1 ①② mm	D mm	E mm	H mm	J mm	L mm	M mm	N mm	W mm
1	12.7	60	33	7.9	42	102	22	37.00	19.00
2	25.4	102	57	9.6	42	111	40	60.00	25.40
3	38.1	127	80	9.6	73	149	55	78.00	25.40
4	50.8	159	108	9.6	94	197	76	95.00	44.40
5	76.2	216	153	12.7	121	267	110	145.00	63.50
5S③④	102.0	267	178	19.1	121	279 / 337	140	180.00	44.4 / 101.6

- ① Bores are furnished for clearance fit unless otherwise specified by customer.
- ② Rectangular keys must be used for maximum bore diameters.
- ③ Size 5S is supplied in two lengths.
- ④ Special hubs can be supplied with dimension W increased to accommodate larger size drive media.

Table 7

Size	Smallest sprocket (No. of Teeth)					Smallest Pulley Diameter ① mm
	3/8" pitch	1/2" pitch	5/8" pitch	3/4" pitch	1" pitch	
1	16	13	11	-	-	42
2	24	19	16	14	11	67
3	30	23	19	17	13	86
4	-	27	22	19	15	115
5	-	40	32	28	22	169
5S	-	49	39	34	26	261

① The pulley diameter quoted is to the bottom of the V-sheave groove or the inside diameter for the flange of the timing pulley. For multiple strand sprockets contact Rexnord Autogard.

Model 209

Figure 5

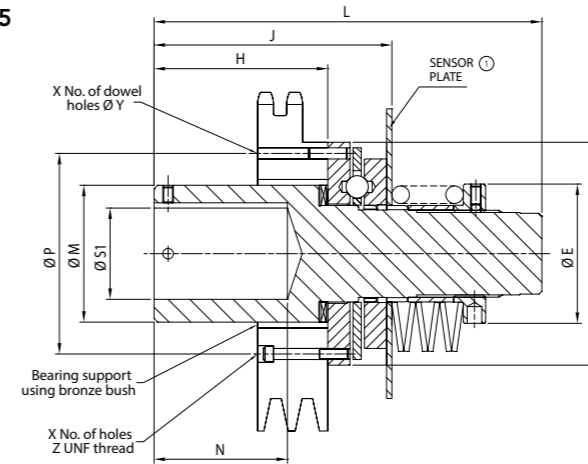

① See page 13, Table 18 for dimensions and movement on disengagement.

Table 8

Size	Torque ①		Speed ②			Weight ③ Kg	Mass Moment of Inertia MR ² ④ Kgm ²
	Type AC or AF Nm	Type ACT Nm	Type AC rpm	Type ACT rpm	Type AF rpm		
1	1-44	3-69	200	500	1800	1.0	0.0005
2	6-226	9-384	200	500	1800	2.9	0.0049
3	6-678	9-854	200	500	1800	7.0	0.0150
4	90-1,130	113-1,774	200	500	1800	16.8	0.0600
5	141-2,540	158-2,937	200	500	1800	42.2	0.2100

- ① See page 14, Table 19 for spring selection and torque range with specific springs.
- ② Higher speeds may be allowed under certain conditions. Please consult Rexnord.
- ③ Weights and moments of inertia apply to maximum S1 bores.

Table 9

Model 209 accommodates applications requiring relatively large "blind" bore and light torque setting. Can be supplied by factory with a bearing-supported sprocket, sheave, etc.

Size	Max Bore S1 ① mm	D mm	E mm	H mm	J mm	L mm	M mm	N ② mm	P mm
1	25.4	60.5	32.8	68.3	96.3	139.7	36.53 / 36.55	57.2	47.63
2	41.3	101.6	56.4	81.0	106.7	152.4	60.30 / 60.33	66.7	90.47
3	57.2	127.0	79.5	104.9	136.9	215.9	78.49 / 78.54	92.0	114.30
4	69.8	158.8	108.0	147.8	187.5	287.5	95.20 / 95.25	130.0	144.45
5	101.6	215.9	152.4	193.5	243.6	368.3	145.24 / 145.29	162.0	196.85

- ① Bores are furnished for clearance fit unless otherwise specified by customer.
- ② Dimension N is depth of blind bore S1 as normally furnished, unless otherwise specified. For through-shaft applications or for weight reduction, a through bore can be furnished at extra charge if clearance permits.

Table 10

Mounting information for sprocket, sheave, etc.

Size	X # of holes	Y in	Z in	I.D. of Bearing if Bronze is utilized mm
1	3	3/16	8/32 UNC	36.60 / 36.63
2	3	3/16	8/32 UNC	60.40 / 60.45
3	①	1/4	1/4 UNF	78.61 / 78.66
4	6	5/16	5/16 UNF	95.35 / 95.40
5	6	3/8	3/8 UNF	145.44 / 145.49

① Size 3 has 6 tapped holes 60° apart and 3 roll pin holes 120° apart spaced 30° between tapped holes.

Model 203

Figure 6

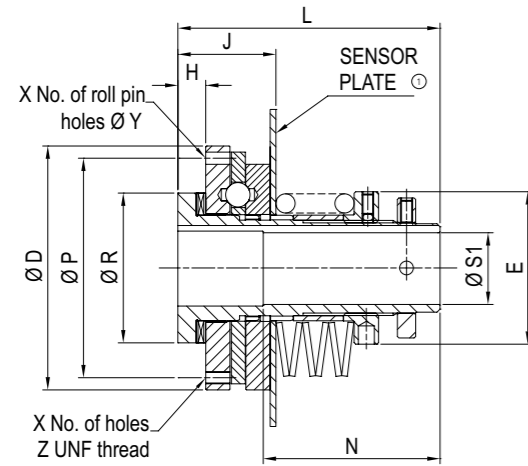

⊙ See page 13, Table 18 for dimensions and movement on disengagement.

Table 11

Size	Torque ⊙		Speed ⊙			Weight ⊙ Kg	Mass Moment of Inertia MR ² ⊙ Kg ^m ²
	Type AC or AF Nm	Type ACT Nm	Type AC rpm	Type ACT rpm	Type AF rpm		
1	1-44	3-69	200	500	2000	1.0	0.0003
2	6-226	9-384	200	500	2000	2.4	0.0030
3	6-678	9-854	200	500	2000	5.4	0.0090
4	90-1,130	113-1,774	200	500	2000	12.7	0.0450
5	141-2,540	158-2,937	200	500	2000	27.9	0.1300
5S ⊙	938-7,627	1,130-8,474	200	500	-	55.0	0.4600

- ⊙ See page 14, Table 19 for spring selection and torque range with specific springs.
- ⊙ Higher speeds may be allowed under certain conditions. Please consult Rexnord.
- ⊙ Size 5S is available in Type AC and ACT resets only.
- ⊙ Weights and moments of inertia apply to maximum S1 bores.

Table 12

Model 203 mounts to the face of a flywheel or large gear by means of a suitable adapter. The flywheel or gear must be mounted on its own bearings.

Size	Max. Bore S1 ⊙ ⊙ mm	D mm	E mm	H mm	J mm	L mm	N mm	P mm	R mm	X # of holes	Y in	Z in
1	12.7	60	33	11.5	39.1	91	50.80	47.625	37	3	3/16	8/32 UNC
2	25.4	102	57	14.4	40.3	95	66.55	90.475	60	3	3/16	8/32 UNC
3	38.1	127	80	14.4	47.9	137	88.90	114.300	78	6 ⊙	1/4	1/4 UNF
4	50.8	159	108	13.2	55.4	165	127.00	144.450	95	6	5/16	5/16 UNF
5	76.2	216	153	27.9	78.5	216	165.10	196.850	145	6	3/8	3/8 UNF
5S	102	267	178	37.1	111.5	234.9	190.50	⊙	180	6	5/8	1/2 UNF

- ⊙ Bores are furnished for clearance fit unless otherwise specified by customer. Rectangular keys must be used on larger bore diameters.
- ⊙ Collars containing set screws to secure the S1 hub to the shaft can be supplied on request. Please consult Rexnord.
- ⊙ Size 3 has 6 tapped holes 60° apart and three roll pin holes 120° apart spaced 30° between tapped holes.
- ⊙ For AC type, P = 235 mm for 1/2" UNF threaded holes and P=209.55 mm for the 5/8" dowel holes; For ACT type, P = 251.46 mm.



Series 200 Applications

- Printing/Book Presses
- Mixers
- Palletizers
- Positive Displacement Pumps
- Cartoners/Case Packers
- Labelling, Filming Machines
- Reel Stands
- Conveyors
- Bottling/Filling Lines

Model 205

Figure 7

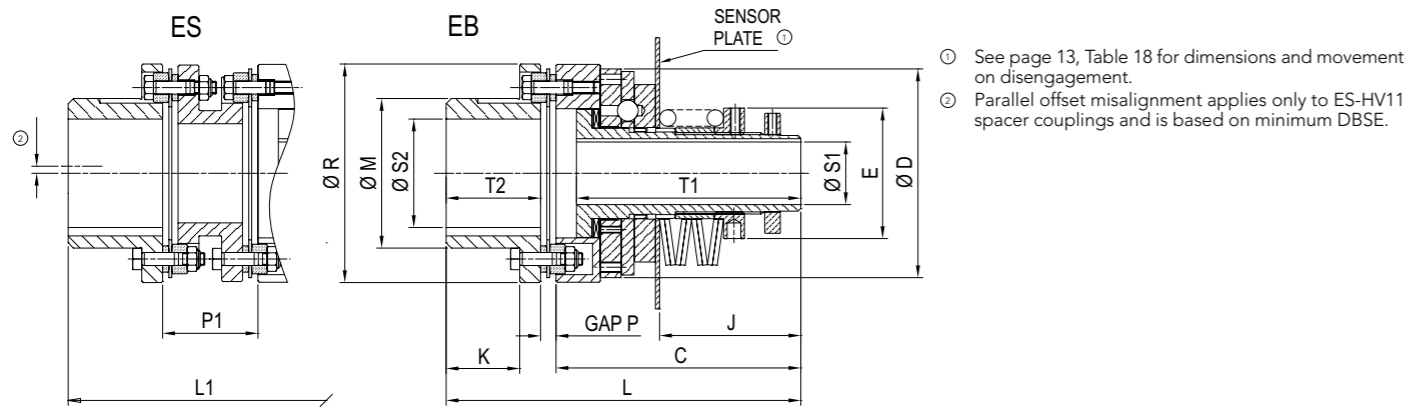

Table 13

Size	Torque ①		Speed ②			Weight ③ Kg	Mass Moment of Inertia MR ² ④ Kg·m ²	Max. Coupling Misalignments		
	Type AC or AF	Type ACT	Type AC	Type ACT	Type AF			Axial	Angular	Parallel ⑤
	Nm	Nm	rpm	rpm	rpm			mm	degree	mm
1/8HVII	1-44	3-69	200	500	2000	2	0.00108	0.3	0.5	0.6
2/35HVII	6-226	9-384	200	500	2000	5.5	0.00607	0.5	0.5	0.7
3/70HVII	6-678	9-854	200	500	2000	10.5	0.01562	0.6	0.5	0.7
4/150HVII	90-1,130	113-1,774	200	500	2000	23	0.07650	0.8	0.5	0.8
5/480HVII	141-2,540	158-2,937	200	500	2000	51	0.27330	1.0	0.5	1.3

- ① See page 14, Table 19 for spring selection and torque range with specific springs.
- ② Higher speeds may be allowed under certain conditions. Please consult Rexnord.
- ③ Weights and moments of inertia apply to maximum (S1 and S2) bores.
- ④ Parallel offset misalignment applies only to ES-HVII spacer couplings and is based on minimum DBSE.

Table 14

Model 205 includes the Autoflex EB-HVII torsionally rigid metal membrane coupling for angular misalignment. The Autoflex ES-HVII can be supplied upon request and accommodates angular and parallel offset misalignment.

Size	Max. Bore S1 ①②	Max. Bore S2 ①②	C	D	E	J	K	L	L1	M	P	P1 ③	R	T1	T2
	mm	mm	mm	mm	mm	mm	mm	mm	mm	mm	mm	mm	mm	mm	mm
1/8HVII	12.7	30	99	60	33	50	23	139	180	43.7	7.4	48	80	90.4	32.5
2/35HVII	25.4	50	108	102	57	51	33	163	212	70.6	9.4	58	110	95.3	46
3/70HVII	38.1	66	149	127	80	86	45	216	265	91	9.4	58	133	136.6	57.5
4/150HVII	50.8	90	179	159	108	106	60	263	318	123	8.8	64	170	165.1	74.6
5/480HVII	76.2	110	231	216	153	135	75	341	435	150	15	109	230	215.9	95

- ① Bores are furnished for clearance fit unless otherwise specified by customer. Rectangular keys must be used for maximum bore diameters.
- ② Collars containing set screws to secure the S1 hub to the shaft can be supplied upon request. Please consult Rexnord.
- ③ P1 dimension is a minimum value. Longer spacers available upon request. Please consult Rexnord.

Model 206N

Figure 8

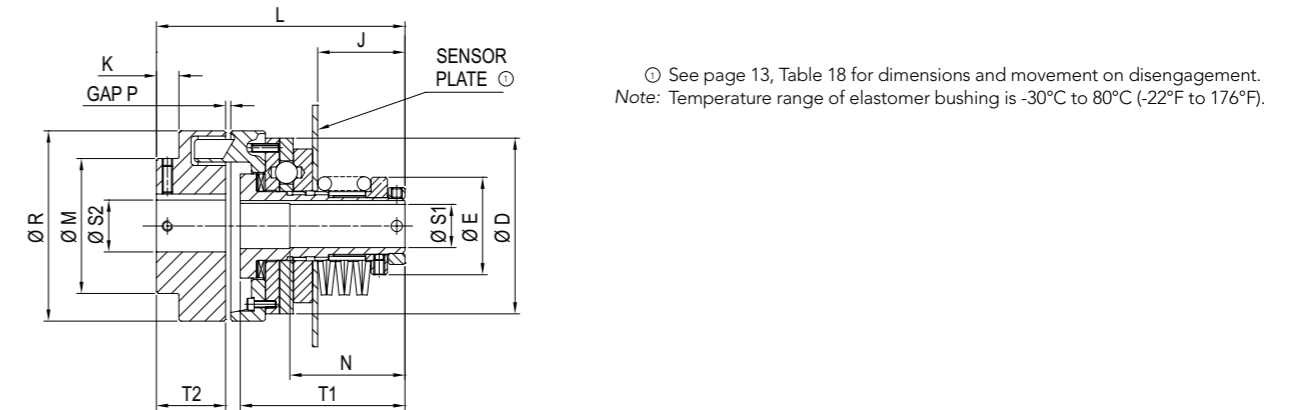

Table 15

Size	Torque ①		Speed ②			Weight ③ Kg	Mass Moment of Inertia MR ² ④ Kg·m ²
	Type AC or AF	Type ACT	Type AC	Type ACT	Type AF		
	Nm	Nm	rpm	rpm	rpm		
1/80	1-44	3-69	200	500	2000	1.7	0.0007
2/110	6-226	9-384	200	500	2000	6.8	0.0050
3/140	6-678	9-854	200	500	2000	11.5	0.017
4/160	90-1,130	113-1,774	200	500	2000	22	0.07
5/250	141-2,540	158-2,937	200	500	2000	56	0.27
5S/350 ⑤	938-7,627	1,130-8,474	200	500	-	120.0	1.50

- ① See page 14, Table 19 for spring selection and torque range with specific springs.
- ② Higher speeds may be allowed under certain conditions. Please consult Rexnord.
- ③ Size 5S is available in Type AC and ACT resets only.
- ④ Weights and moments of inertia apply to maximum (S1 and S2) bores.

Table 16

Model 206N includes a traditional torsionally soft flexible coupling for parallel and angular misalignment.

Size	Max. Bore S1	Bore S2		D	E	J	K	L	M	N	P	R	T1	T2
	mm ①	Min mm ②	Max mm ②	mm	mm	mm	mm	mm	mm	mm	mm	mm	mm	mm
1/80	12.7	-	30	60	33	50	9.53	118.9	50	50.80	3	80	90.4	30
2/110	25.4	-	48	102	57	51	6	143.8	86	66.55	3	110	95.3	40
3/140	38.1	-	60	127	80	86	21	208	100	88.90	3	140	136.6	55
4/160	50.8	-	65	159	108	106	21	243.8	108	127.00	4	160	165.1	60
5/250	78	46	100	216	153	135	40	335.8	165	165.10	5.5	250	215.9	100
5S/350	102	90 ③	140	267	178	120	66.0	422.3	230	190.50	5.5	350	234.9	140

- ① Bores are furnished for clearance fit unless otherwise specified by customer.
- ② Smaller bores may be available under certain conditions. Please consult Rexnord.

Table 17

Minimum S2 Bore and maximum allowable misalignment.

Size	S2 (min) mm	Allowable Misalignment			Gap Between Hub and Adapter	
		Axial mm	Angular Degrees	Parallel mm	Min. mm	Max. mm
1	10	4	0.09	0.13	2.0	4.0
2	14	4	0.09	0.18	2.0	4.0
3	18	4	0.10	0.23	2.0	4.0
4	22	6	0.10	0.28	2.0	6.0
5	48	8	0.10	0.43	3.0	8.0

Engineering Information

Torque Adjustment

The 200 Series can be shipped from the factory with the torque setting specified at the time of order. Alternatively, the unit can be furnished unset allowing for adjustment at the time of installation. Calibration spacers (see Figure 12) are supplied either to prevent this nominal setting being exceeded or to prevent adjustment over the maximum capacity of the unit. Calibration spacers, which are fitted to prevent adjustment above the nominal setting, must be removed to allow the tightening of the adjustment nut to achieve a higher torque not greater than the maximum for the unit. The spacers also help position disc springs correctly where they are used.

In many cases, the exact torque requirements are difficult to calculate with any reasonable degree of accuracy; therefore, the recommended installation procedure is to start the drive with a

low-torque setting, progressively tightening the adjustment nut until the 200 Series starts the mechanism without disengaging. Before attempting to turn the adjusting nut, ensure that the locking screw is loosened and is relocked after final adjustment.

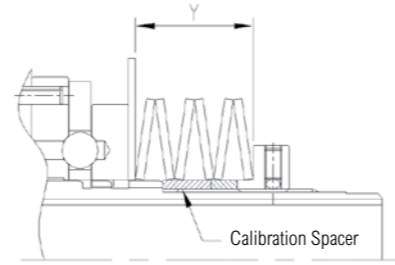

Figure 10

Drive Shutdown on Disengagement

It is necessary to shut down the drive quickly after disengagement upon overload. We recommend all applications use an automatic mechanism to switch off the drive motor. On the 200 Series, a flat limit switch plate for actuating a control

to shut down the drive is furnished at no charge. The flat limit switch plate or sensor plate is used to actuate an Autogard remote shutdown control or equivalent shown in Figure 17 using dimensions in Table 24.

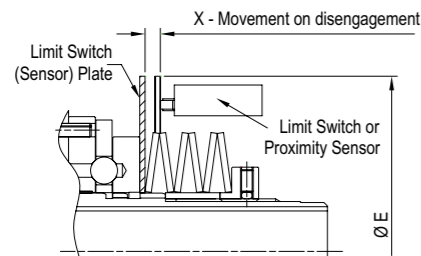

Figure 9

Protective Finish

The standard protective finish applied to the 200 Series is manganese phosphate plus oil dip. This treatment provides a high level of protection with good corrosion resistance and is

suitable for most environments. Other finishes can be applied for situations where exceptional environments necessitate high levels of protection — consult Rexnord.

Table 18

Size		1	2	3	4	5	5S
X	mm	2.4	4.4	4.4	5.3	6.3	8.1
E	mm	83	140	165	203	305	305

Spring Selection

The full range of torque for each size unit is achieved by a number of positions in which coil springs are located. For these sizes, select the proper spring assembly so that the desired tripping torque will fall approximately in the middle of the torque range for that spring. If the spring length in field adjustment

approaches minimum 'Y' dimension, a spring with a higher torque range should be considered.

Calculate theoretical running torque at a chosen location using the following formula: $Torque (Nm) = \frac{Kw \times 9550}{rpm}$

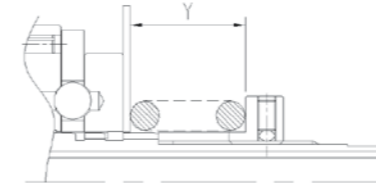

Figure 11

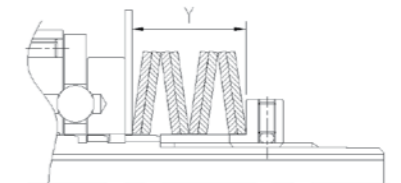

Figure 13

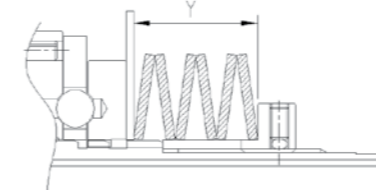

Figure 12

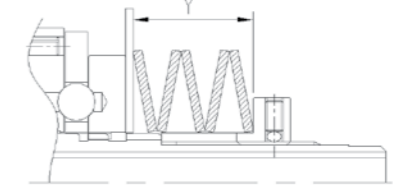

Figure 14

Table 19

Size	Type	Spring Code	Color	Qty.	Stack As	AC/AF Torque Range	ACT Torque Range	Min. Allowable Spring Length Dimension Y
						Nm	Nm	mm
1	Disc	1D/1/S	Natural	6	Figure 13	8 - 44	13 - 68	13
	Coil	1C/1	White / Red	1	Figure 11	9 - 28	10 - 37	23
	Coil	1C/2	White / Green	1	Figure 11	5 - 14	7 - 21	21
	Coil	1C/3	White / Yellow	1	Figure 11	1 - 6	3 - 11	18
2	Disc	2D/1/S	Blue / Black	6	Figure 13	130 - 226	209 - 384	24
	Disc	2D/2/S	Blue	5	Figure 14	72 - 203	102 - 328	23
	Coil	2C/1	Blue / Red	1	Figure 11	54 - 88	102 - 133	25
	Coil	2C/2	Blue / Green	1	Figure 11	21 - 61	40 - 90	21
	Coil	2C/3	Blue / Yellow	1	Figure 11	6 - 19	10 - 25	19
3	Disc	3D/1/D	Brown / Black	8	Figure 12	136 - 678	157 - 854	30
	Disc	3D/1/S	Brown	6	Figure 13	72 - 407	95 - 542	24
	Coil	3C/1	Brown / Red	1	Figure 11	37 - 282	57 - 406	37
	Coil	3C/2	Brown / Green	1	Figure 11	15 - 135	23 - 132	31
4	Coil	3C/3	Brown / Yellow	1	Figure 11	6 - 56	9 - 80	25
	Disc	4D/1/S	Orange / Black	5	Figure 14	222 - 1130	269 - 1774	32
	Disc	4D/2/S	Orange	6	Figure 13	145 - 847	171 - 1073	33
5	Coil	4C/1	Orange / Red	1	Figure 11	90 - 316	113 - 395	49
	Disc	5D/1/S	Grey / Black	6	Figure 13	497 - 2540	543 - 2937	57
	Disc	5D/2/S	Grey	6	Figure 13	226 - 2260	272 - 2655	43
5S	Coil	5C/1	Grey / Red	1	Figure 11	142 - 350	159 - 531	48
	Disc	5SD/1	Natural	5	Figure 14	938 - 5650	1130 - 6440	48
	Disc	Hi-Torq	Natural	5	Figure 14	1413 - 7627	1582 - 8474	53

CAUTION! DO NOT TIGHTEN THE ADJUSTING NUT SO THAT THE SPRINGS ARE COMPRESSED BEYOND THEIR MINIMUM OPERATING LENGTH, DIMENSION 'Y' (with the torque limiter engaged) or the springs will not allow sufficient movement of the slide plate to let the balls leave their seat during an overload. Damage to the machinery or to the 200 Series will result. It is important that Autogard products is used in the correct manner and that adjustment and setting in relation to a particular function follow recommended procedures.

200 Series Industries

Printing and Packaging
Paper Converting
Food and Beverage
Material Handling
Automotive Manufacturing

Maintenance and General Safety Information

Maintenance

The frequency of maintenance will depend on the operating environment and number of trips, but once every 2,000 operating hours should be adequate in most applications. The amount of maintenance required is dependent upon the operating conditions and should be maintained at least as frequently as the adjacent drive components. In adverse conditions, consult Rexnord.

General Safety

Autogard Torque Limiters are reliable units, built to high standards of workmanship. Similar to all mechanical devices, each application must be considered on its own merits with reference to safety (i.e. lifting equipment, explosive conditions, etc). As rotating components, adequate guarding must be provided, in accordance with local codes. The intended use of torque limiters is for the protection of industrial machinery and should not be regarded as human safety devices. Rexnord staff are always available to discuss particular applications.

Other Autogard Products



Autogard Torque Limiter 320 Series



Autogard Torque Limiter 400 Series



Autogard Torque Limiter 600 Series



Autogard Torque Limiter 820 Series



Autogard Torque Limiter WT Series



Any questions? Please contact us.

Morskate Aandrijvingen BV
Oosterveldsingel 47A
7558 PJ Hengelo (Ov)
The Netherlands

NL
T +31 (0)74 - 760 11 11
info@morskateaandrijvingen.nl
www.morskateaandrijvingen.nl

DE
T +49 692 - 222 34 95
info@morskateantriebstechnik.de
www.morskateantriebstechnik.de

EN
T +31 (0)74 - 760 11 11
info@morskatedrivetechnology.com
www.morskatedrivetechnology.com